

AIRCORR T-OEM

RS-485 Modbus transmitter for real-time monitoring of environments corrosivity

Real-time information on environments corrosivity is essential for the effective protection of valuable equipment and assets against corrosion. The AIRCORR T transmitter, tracks changes over time of the electrical resistance (ER) of a thin metallic sensor. If the metal corrodes, the cross-sectional area of the sensor decreases and the ER increases. The changes in ER can be then directly translated into corrosion depth and corrosion rate. The RS-485 communication protocol of the AIRCORR T offers the possibility to connect multiple transmitters and ER sensors to a unique data logger. When compatible, a remote access to the data logger can be established, allowing for real-time data reading and processing, e.g. using a dashboard. The AIRCORR T monitoring system consists of three main parts:

- Electronic transmitter (AIRCORR T) for measuring and transmitting ER;
- Metal ER sensor that actually corrodes in the environment;
- Data logger^[1] that controls transmitter(s) and record data;

Main features

- **Compatible with any RS-485 Modbus data logger.**
- **Multiple AIRCORR T transmitters** can be connected to a **unique data logger**.
- Possibility to get a **remote access to data** using a compatible data logger.
- Thanks to the great precision of the electronic device and the geometry of the metal track, both a **quick response time** and a **highly sensitive measurement** are achieved.
- **A wide range of sensors compatible** with the AIRCORR T is available.
- New **robust sensor design** with cable lengths available up to 100 meters.



**AIRCORR T
TRANSMITTER**



**RACK OF AIRCORR T
TRANSMITTERS**

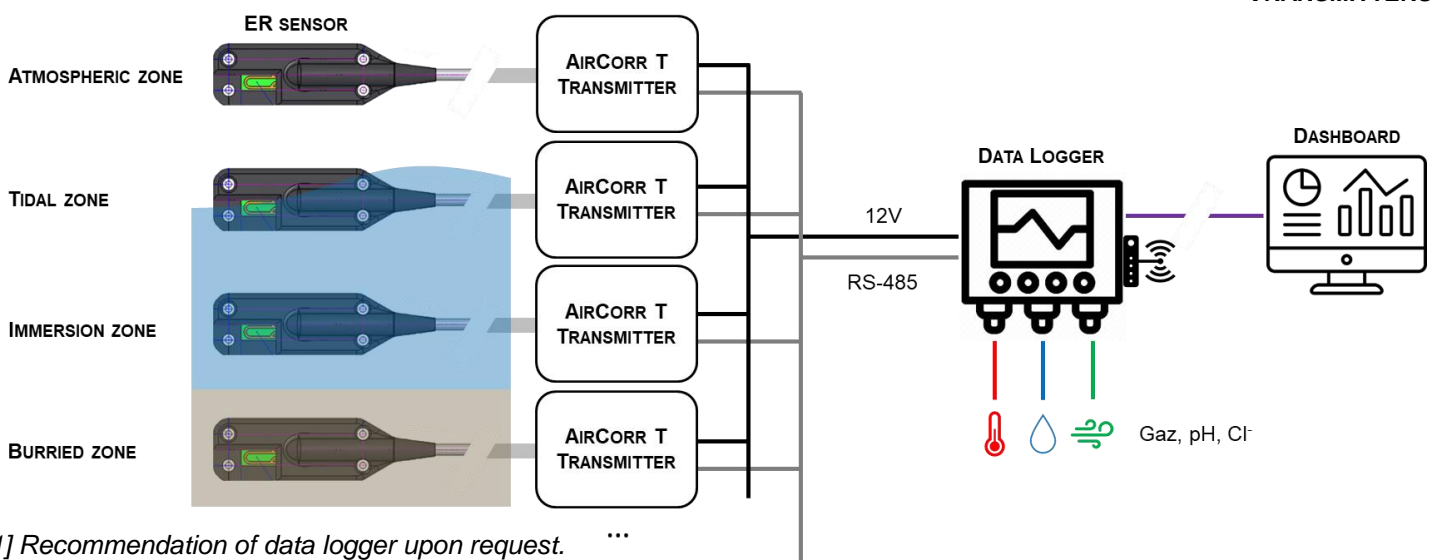

[1] Recommendation of data logger upon request. ...

Specifications

AIRCORR T

General

Dimensions, weight	100 mm x 100 mm, 80 g
Optimal / max. operating temperature	from 0 to 30 °C / from -5 to 45°C
Mounting arrangements	x4 M3 clearance holes (rack upon request)

Communication protocol & Electrical

Communication protocol	Modbus RTU, RS-485, 2-wire , half duplex
Supply voltage	+12V nominal (max. 10V to 14V)
Current consumption	100 mA to 400 mA / transmitter
Electromagnetic compatibility (EMC)	as per IEC 61000-4-3, IEC 61000-4-5, IEC 61000-4-6

Measurement

Resistance ranges (Factory-set)	0.005 – 0.05 Ω
	0.01 – 0.1 Ω
	0.1 – 1.0 Ω
Accuracy	<0.3% of sensor thickness
Resolution	<0.01% of sensor thickness
Frequency	from 1/30second to 1/day

ER sensors

Sensor	Sensing material	Resistance range [Ω]	Life span [μm]	Resolution ^[2] [nm]
Fe-250μm	Carbon steel (AISI 1010)	0.01–0.1	125	200
Fe-25μm ^[3]	Carbon steel (AISI 1010)	0.1–1	12.5	3
Zn-50μm ^[4]	Zinc	0.1–1	25	7
Cu-12μm ^[3]	Copper	0.1–1	6	4
Al-20 μm ^{[3][4]}	Pure aluminium (AA 1050)	0.1–1	-	-
AlCu-125μm ^{[3][4]}	Aluminium copper (AA 2219)	0.01–0.1	-	-
AlZn-125μm ^{[3][3]}	Aluminium zinc (AA 7075)	0.01–0.1	-	-

Other materials upon request

^[2] Minimum measurable change in the corrosion depth assessed in laboratory conditions. ^[3] Available upon request.

^[4] Indicative ER corrosion depth and corrosion rate due to localised corrosion affecting aluminium alloys.

Contact

Johan BECKER
johan.becker@institut-corrosion.fr
Tel: +33 (0) 2 98 05 15 52



220 rue Pierre Rivoalon, 29200 Brest, France
Tel: +33 (0)2 98 05 15 52 - www.institut-corrosion.fr